

150

FLUEBOOST

f l u e b o o s t 1 5 0



The flueboost is a box shaped unit with in line spigots for the flue connection, a pressure switch to ensure safe operation, all within a compact package.

H E L P L I N E

01565 755599

150

FLUEBOOST 150

Flueboost Installation and Technical Specification



CAPACITY AND RANGES

It will handle flue gases at up to 200 Deg.C and boilers with heat outputs up to 150,000 Btu/h; 44Kw/h, dependant on size and length of flue. (Normal secondary flue temperatures of the average gas appliance working at 75% efficiency are 180 Deg.C with a CO² at 5%)

GAS FIRE CONVERSION

This unit can be converted for gas fires by use of a factory fitted circuit board which has no pre purge. Please contact Flueboost if this option is required.

MOTOR COOLING

The motor is fixed speed and has an external rotor with secondary cooling impeller, Class F windings and maintenance free sealed ball bearings with adequate lubrication to ensure reliable operation for many years.

CONNECTIONS

The unit is supplied with a 4 core type 'yy' cable. The cores are numbered 1 to 3 and yellow/green. No.1 is live, No.2 is neutral and No.3 is switched live at 220/240volt.

PRESSURE SWITCH

The pressure switch has contacts which close with airflow and open if flue becomes blocked or fan failure.

TIME DELAY

The fan has a built in pre purge period of 30 seconds. This is to purge the appliance of any gases before boiler ignition. Gas fire models have no pre purge.

INSTALLATION AND MAINTENANCE

Full instructions on installation and operating come with the unit. If service or repairs are required the working parts can be removed as a sub assembly without disturbing the main case.

FINISH

The unit is constructed from mill finish grade 304 stainless steel.

ELECTRICAL DETAILS

230 Volt; Single Phase; 40watt.

Starting current 1.2 Amp.

Running current 0.18 Amp.

Unit fuse in control unit.

WEIGHT

6.2 Kg.

SOUND LEVEL

Less than 70dBa at 1 Metre.

Note: This appliance must have a draught diverter or draught stabiliser fitted within the primary flue section.

F L U E B O O S T H E L P L I N E

01565 755599

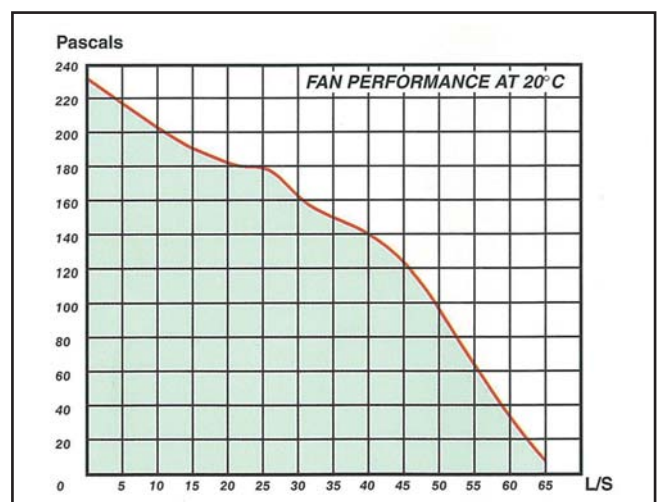
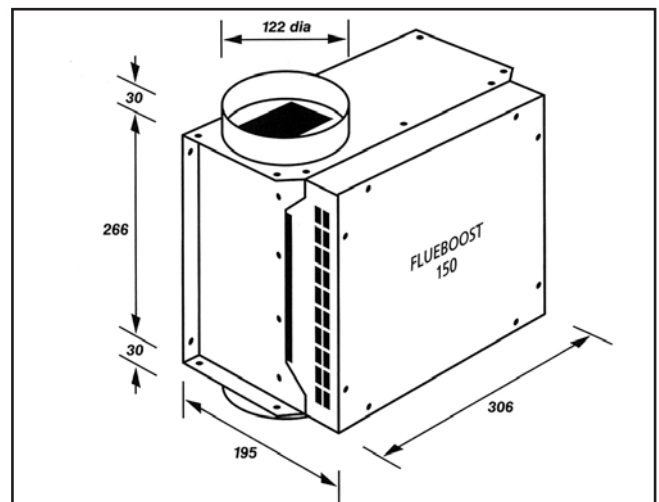
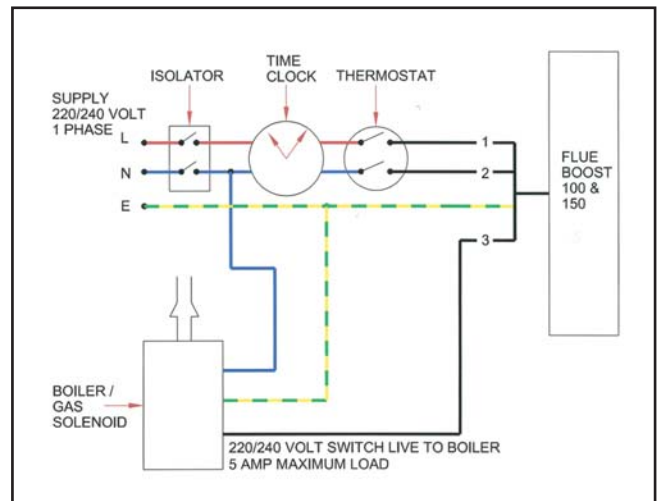
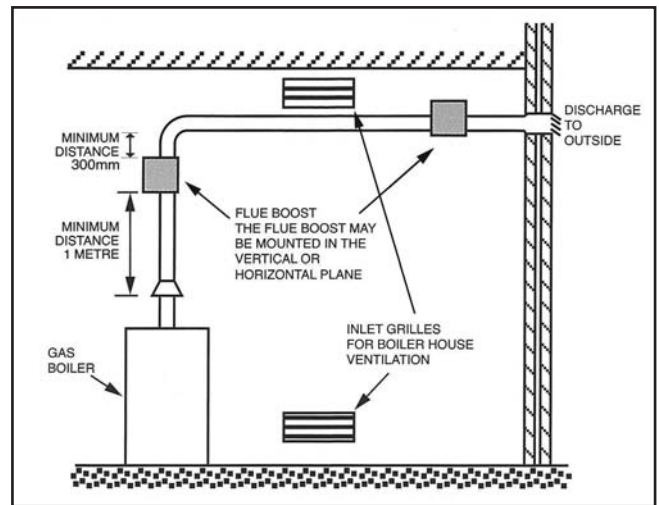



Model: FB150



Original Document

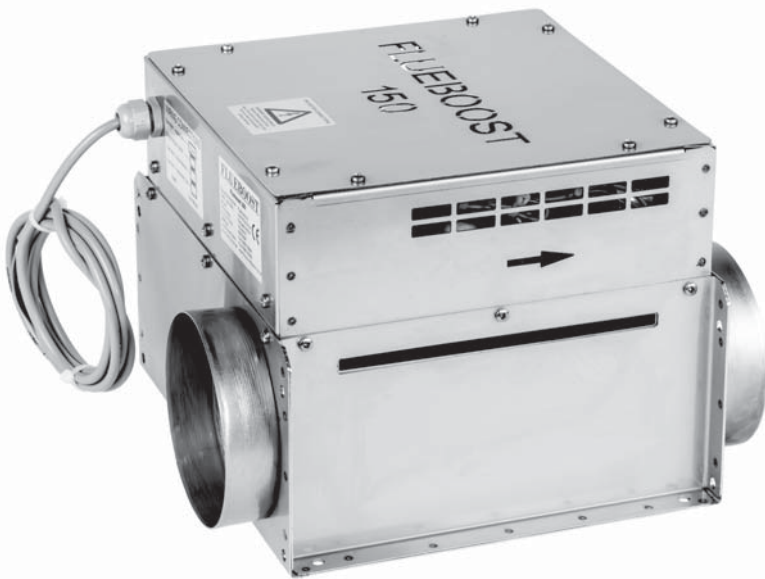

H E L P L I N E

01565 755599

Model: FB150

DESCRIPTION

The Flueboost FB150 is an inline centrifugal fan designed to evacuate the products of combustion within the flue. The unit is single speed and contains a pressure switch to ensure failsafe operation.

FB150 MAIN COMPONENT PARTS

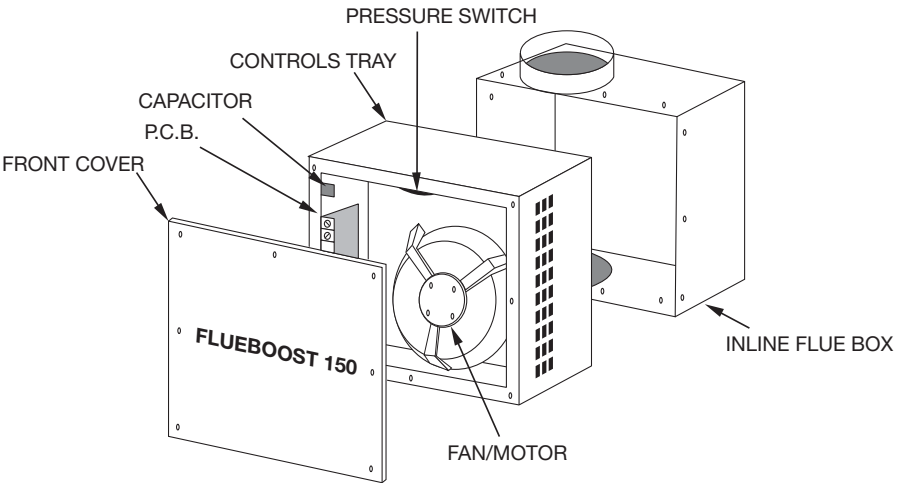

FLUEBOOST 150 UNIT SPECIFICATIONS

Series 150

44Kw / 150,000 Btu

Maximum operating temperature

Flue gas temperature 200 Deg C

Ambient air temperature 40 Deg C

Electrical details

Supply 230V / 1Ph / 50Hz

Supply lead – 2 metre x 0.75mm, type YY x 4 core flex

Fan motor

40 watt. Class 'F' windings

Starting current – 1.2 Amp

Running current – 0.18 Amp

Motor speed 1920 R.P.M.

Time delay

30 second pre purge

Flue spigot details

122 mm I.D.

Construction

Case – Grade 304 stainless steel

Main impeller – aluminium

Cooling impeller – galvanised steel

Weight

6.2 Kg

Note: This appliance must have a draught diverter / draught stabiliser fitted within the primary flue if fitted to a boiler.

ELECTRICAL INSTALLATION

It is strongly recommended that all electrical installation work is carried out by a qualified electrician and that all wiring must conform to the relevant codes of practice and IEE Regulations.

Mains supply must be 230V / 1Ph / 50Hz

The Flueboost unit must be correctly earthed – a double pole fused (5Amp class F) isolating switch must be incorporated into the basic wiring circuit.

Note: In all installations it is essential that the Flueboost is connected in the supply circuit between the appliance controls and the gas valve, so in the event of fan failure the gas valve will remain shut.

UNIT WIRING

The wiring diagram below is of a typical scheme to illustrate the modifications into the basic circuit.

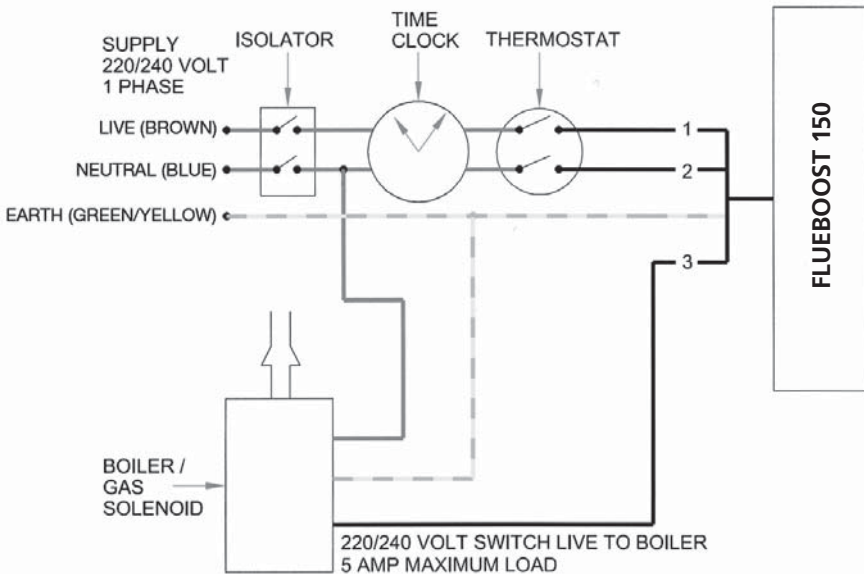

SAFETY

Ensure, before switching on, that no parts have been removed and that all screws etc are tight. Failure to check might result in a safety hazard. Operation on the mains supply other than that stated might result in damage to the fan components and produce a hazardous situation.

MATERIALS AND FIRE CHARACTERISTICS

The materials employed in the manufacture of these fans do not constitute a fire hazard. A correctly installed fan is not subject to self-ignition. The terminal block, P.C.B. motor winding and wiring may give off a small quantity of toxic fumes in the event of a fire source external to the fan. The materials used in these components are all self-extinguishing. The majority of the unit utilizes noncombustible materials.

INSTALLATION

The fan should be mounted as per detailed instructions. Any other method of mounting must be approved by Flueboost in writing.

The Flueboost fan may be positioned anywhere in the primary flue providing that the following points are adhered to; install the fan at least 300mm away from the nearest bend or elbow and 1m away from the boiler/draught diverter.

See figure 1 for installation guidance.

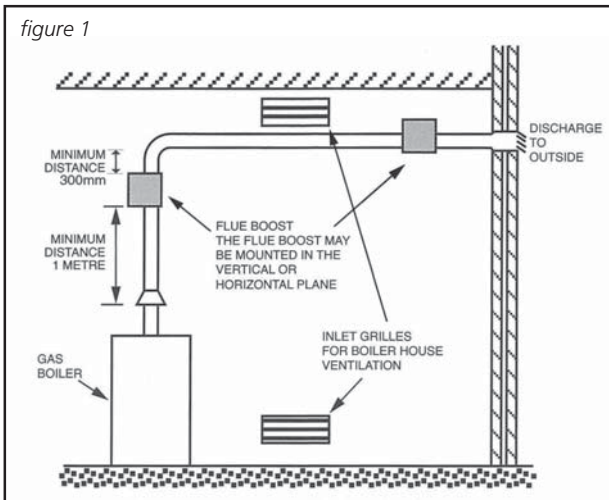

INSTALLATION

The flue pipe size must be as the boiler manufacturer states; any conversion must only be made at the fan.

The front cover must be on a vertical plane or on top but never be facing down.

The front cover must never be placed against a wall.

The fan must never be encased.

The minimum free air for combustion is as the boiler manufacture states plus 10% extra for the Flueboost. This is to be via two fresh air vents, the upper must be above the Flueboost to allow air to circulate around the fan for cooling. The maximum ambient air temperature being 40 Dec C.

The Flueboost is for 230V/ 1Ph /50Hz appliances only.

Air must be allowed to pass through the fan on start up this must be via a draught diverter / draught stabiliser.

The direction of flow is indicated on the side of the fan in the form of an arrow.

Should another fan be in the same room as the Flueboost/boiler, please contact Flueboost prior to installation as it may affect the performance of the Flueboost.

When fitting the Flueboost into the flue, the gap between the spigot and the flue duct should be caulked with a suitable material, i.e. fire cement, high temperature silicone, etc.

These fans are not suitable for use in any environment containing corrosive, flammable gases, dust or high ambient temperature 40 Deg C maximum.

The fan is to be installed internally only (not external), and must never come into contact with liquids.

INSTALLATION RECOMMENDATIONS

Atmospheric gas fired appliance

If the fan is fitted to a modular boiler system it is recommended that dampers are fitted within the primary flue system to balance out the draught. This prevents the fan pulling all the air from the nearest riser – if this is not done then the appliance draught diverter furthest from the fan may spill.

High efficiency gas appliance

A problem which may occur on high efficiency gas appliances is that of condensation, which will be in the form of dense plumes of condensation forming at the flue terminal, this will reduce as the flue system reaches working temperature, should the problem persist it may be due to the fan running too fast and entraining too much free air into the flue system, causing the flue products to fall below the dew point. Problems may occur within the flue system due to pools of condensation forming; if this is envisaged then the design of the flue should take this into account i.e. in the form of condensate traps; insulated flue and incline of flue to the condensate traps.

Oil fired / sealed gas fired appliances

NOTE: On both these applications a draught diverter must be fitted within the primary flue section, i.e. the draught diverter must be fitted between the boiler and flue fan, failure to do so will make the fan inoperable, this is due to the fan being starved of air during the pre-purge period. This problem arises due to the fact that the boiler systems have no natural draught produced through them, the draught stabiliser allows air to be drawn into the flue system and trigger the pressure switch in the pre-purge period which allows the fan to trigger ignition of the boiler.

Oil fired appliance flue temperatures are in the region of 320/380 Deg C. and the use of a draught stabiliser will cause the fan to entrain cool air into the flue system, thereby reducing the flue temperature below 300 Deg C.

Condensing boilers

If the flue boost is to be fitted to a condensing boiler, provision must be made so that condensate cannot fall back into the fan, this should be done via condensate traps that are plumbed in accordingly.

Bio mass boilers

The fans may be installed with bio mass boilers providing the fuel used is dry pellets; the fan main impeller must be cleaned annually, preferably twice a year with this application.

Please note these fans cannot be installed if the fuel is moisture laden wood chips.

MAINTENANCE

No special attention is required. The oil capacity in the pre-oiled and sealed bearings is more than adequate to ensure reliable operation of the Flueboost for many years.

At the same time, the opportunity should be taken to remove dust or foreign matter on and around both the unit cooling and main impellers. These operations can be effected as follows.

- Isolate the Flueboost unit from the mains electric supply.
- Remove the front cover via 8 x M4 screws.
- Release the 12 x M4 screws securing the controls tray to the flue box, the controls tray may now be withdrawn.
- Both the cooling and main impeller may now be cleaned with a light brush.
- Check the pressure switch for satisfactory operation.
- Re-assemble the Flueboost and reconnect to the mains electric supply.
- In the event of a fan failure, isolate from the mains electric supply before attempting to identify the cause.

Note

The Flueboost is designed so that it is not necessary to remove the main flue box from the flue ducting for either repair or maintenance. All working parts may be removed via the controls tray as a sub assembly.

WARNING

Never remove the front cover without first disconnecting the mains electric supply.

This fan must never be exposed to liquids. If a liquid accidentally splashes over the fan immediately disconnect the fan from the mains electric supply, clean and dry thoroughly before reconnecting.

SAFETY INFORMATION

1. Inspection of goods upon receipt

Check the information on the fan case label and ensure that the goods are compatible with your requirements, inspect for any sign of damage including internal i.e. parts may have broken free and report any damage immediately to the supplier – do not install or use a damaged fan.

2. Storage

Store in a dry clean environment.

3. Handling

When handling the fan never allow its weight to bear on the cable or electrical fittings.

4. Safe use

Do not use the fan in an environment containing flammable or corrosive gasses or dust. The fan must be fitted within the flue system so that the impellers are guarded i.e. not accessible.

Ensure, before switching the flue fan on, that no parts have been removed and that all screws etc. are tight - failure to do so might result in a safety hazard.

Operating the fan on an electrical supply other than 230V / 1Ph / 50Hz will damage the fan and produce a hazardous situation.

In the event of a fan failure, isolate the fan from the mains electric supply before attempting to identify the cause; this is of particular importance due to the fan having rotating parts within the controls tray. The fan must never be exposed to liquids. If a liquid accidentally spills over the fan, disconnect the fan from the mains electric supply, clean and thoroughly dry before inspecting. After satisfactory inspection of both the fan and installation, then it may be considered operational, providing the health and safety requirements are met; as specified within the Machinery Directive 89/392 and current revisions.

5. Supply voltage

230V / 1Ph / 50Hz

6. Material content

The materials employed in the manufacture of this fan do not constitute a hazard.

7. Fire characteristics

A correctly installed fan is not subject to self ignition. The terminal block; wiring loom; P.C.B. and motor may give off a small quantity of toxic fumes in the event of a fire external to the fan. The materials used for these components are self extinguishing.

8. Disposal

No special hazards are envisaged. Do not dispose of by incineration.

RETURNS POLICY

If the product is not no longer required and returned to us within 14 days of purchase in the original packaging then we will offer a full refund – less a 20% re-stocking charge (subject to inspection of the goods).

Any goods returned after this time will considered on an individual basis and only a credit against a future purchase will be offered.

GUARANTEE

Flueboost Ltd guarantees its products for 12 months from the date of purchase against faulty materials or workmanship. In the event of any part being found defective the product will be repaired, or at the companies discretion replaced, without charge, providing the product:

- Has been installed and used in accordance with the instructions provided with each unit.
- Has not been connected to an unsuitable electric supply.
- Has not been subject to misuse, neglect or damage.
- Has not been modified or repaired by any person not authorised by the company.

If Claiming Under Terms of Guarantee

Please return the complete product, carriage paid by your original supplier or to Flueboost Ltd, ensuring it is adequately packed and accompanied by a letter clearly marked **GUARANTEE CLAIM** stating the nature of the fault and evidence of the date and source of purchase.

This guarantee is offered as a benefit, and does not affect your legal rights.

Consequential Claims

May we remind you that our guarantee covers replacement or repair by ourselves of the goods agreed by us as faulty. It does not include reimbursement of costs incurred unless specifically agreed in advance in writing. Agreement of this type can only be authorised from the appropriate person at Flueboost Ltd, no one else is authorised to alter or modify our terms of guarantee.



Unit 6 The Grove
Parkgate Industrial Estate
Knutsford
Cheshire WA16 8XP

T: 01565 755 599
F: 01565 755 055
E: info@flueboost.co.uk

www.flueboost.co.uk

July 2014